

**ZEUS** HYDRATECH LTD  
*Global Suppliers of Premium Hydraulic Components*

**Official UK Distributor for Auburn Gear Power Wheel Drives**

T: +44(0)1172 130042. E: [sales@zeushydratech.com](mailto:sales@zeushydratech.com). W: [zeushydratech.com](http://zeushydratech.com)

# AuburnGear

Engineered Drive Solutions



## Power Wheel® Model 7 Planetary Gear Drives

260.925.3200

AuburnGear.com



Model 7 Features & A2 Integral Brake  
Information.....3

**WHEEL DRIVES**

Standard Configurations.....4-5  
with A2 Integral Parking Brake.....6-7

**SHAFT & SPINDLE OUTPUT DRIVES**

Standard Configurations.....8-9  
with A2 Integral Parking Brake.....10-11

**SHAFT INPUT/OUTPUT DRIVES**

Standard Configurations.....12-13

**OPTIONS**

Output Shafts.....14

**INFORMATION**

Other Options.....15  
Lubrication Data.....15  
Warranty.....15



# Power Wheel® Model 7 Features

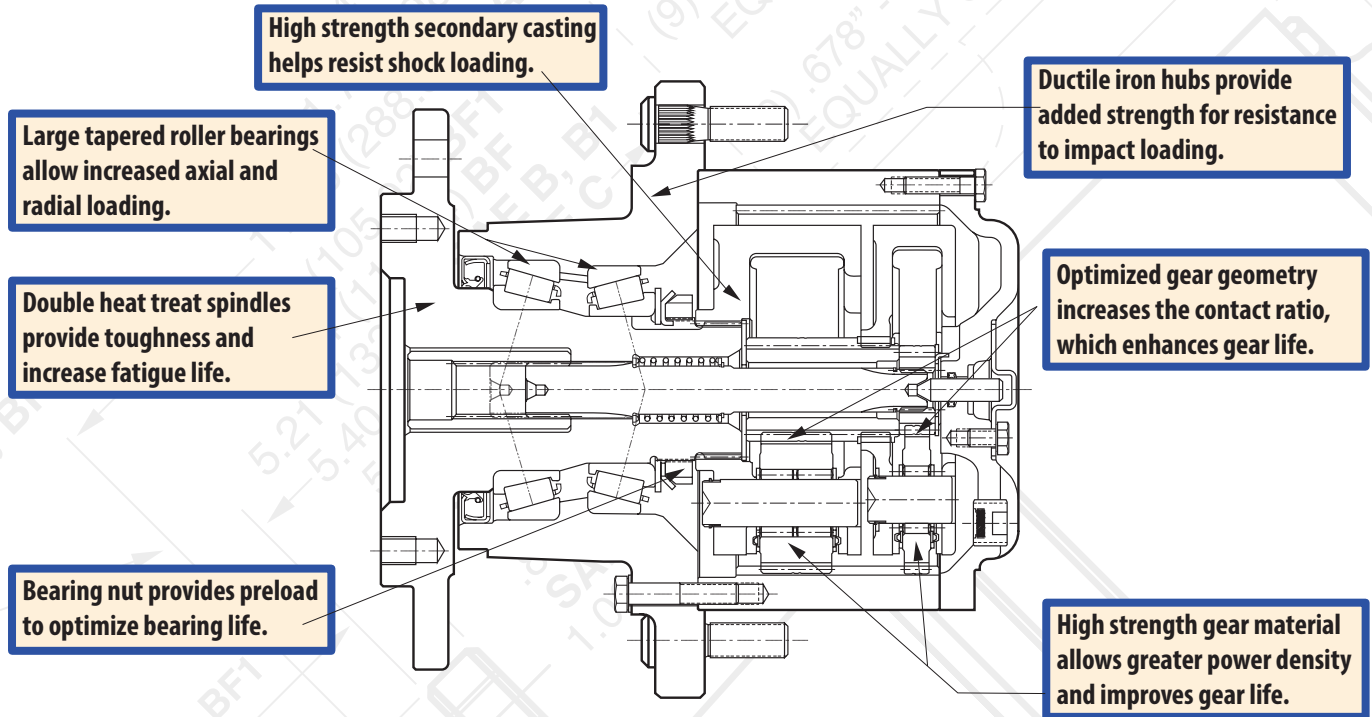

## Power Wheel® Model 7 Features A2 Series Integral Parking Brake

### GENERAL A2 SERIES DATA:

1. Maximum operating pressure is 3,000 psi (206.4 Bar). Pressure spikes or surges not to exceed 3,500 psi (240.8 Bar). Surge pressure in excess of 3,500 psi (240.8 Bar) caused by spikes in the hydraulic system could shorten brake life and must be avoided.
2. Use only SAE grade 8 mounting bolts and torque to 80-90 lb. ft. (108-122N-m) for motor mounting.
3. **PRECAUTION:** Bench testing may cause distortion of components or bolt failure. Mounting bolts must be used for supplemental clamping.
4. Minimum Release Pressure is defined as the hydraulic pressure required to obtain full running clearance.
5. Cubic Inch Displacement is the volume of oil required to release the brake piston 1.0 in<sup>3</sup> (16.4cc) for a new brake and 2.0 in<sup>3</sup> (32.8cc) for a worn brake pack.

**PISTON:**  
Improved design for superior life at higher pressures

**FRICION DISCS:**  
"Heavy Duty Graphitic Paper" for wet sump applications.  
**Characteristics:**  
Superior energy capability, high and stable coefficient of friction and smooth engagement.

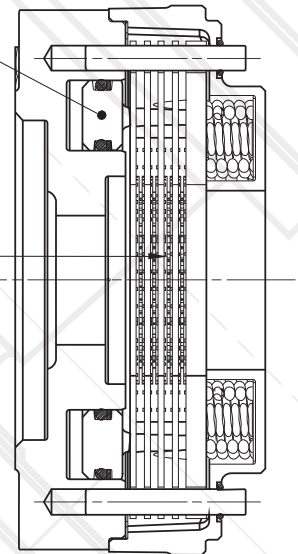

### BRAKE RATINGS

MODEL	TORQUE	MINIMUM RELEASE PRESSURE	STYLE
B1	1,540 lb-in (174 N-m)	190 PSI (13.1 BAR)	Short
B2	1,800 lb-in (203 N-m)	220 PSI (15.1 BAR)	Short
B3	2,400 lb-in (271 N-m)	290 PSI (20.0 BAR)	Short
B4	2,400 lb-in (271 N-m)	160 PSI (11.0 BAR)	Long
B5	3,200 lb-in (362 N-m)	220 PSI (15.1 BAR)	Long
B6	3,600 lb-in (407 N-m)	230 PSI (15.8 BAR)	Long
B7	4,200 lb-in (475 N-m)	260 PSI (17.9 BAR)	Long

Maximum Release Pressure 3,000 PSI (206.4 BAR)

# Model 7 Wheel Drives Double Reduction

## General Specifications

Max. intermittent output torque<sup>1</sup> .....70,000 lb-in (7,910 Nm) Approximate Weight ..... 120 lbs (54kg)  
 Max. input speed .....5,000 RPM Approximate Oil capacity..... 31 oz (920 cc)

For Lubrication Data, see Page 15

<sup>1</sup>Depending on the duty cycle and the nature of the application, a normal continuous output torque of 1/3 to 1/2 of the maximum Intermittent should yield satisfactory Power Wheel® life. Also, due to the Model 7's unique combination of small physical size and high torque potential, thermal capacity may become limiting factor.

Customer testing and application analysis is strongly recommended.

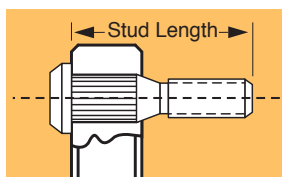
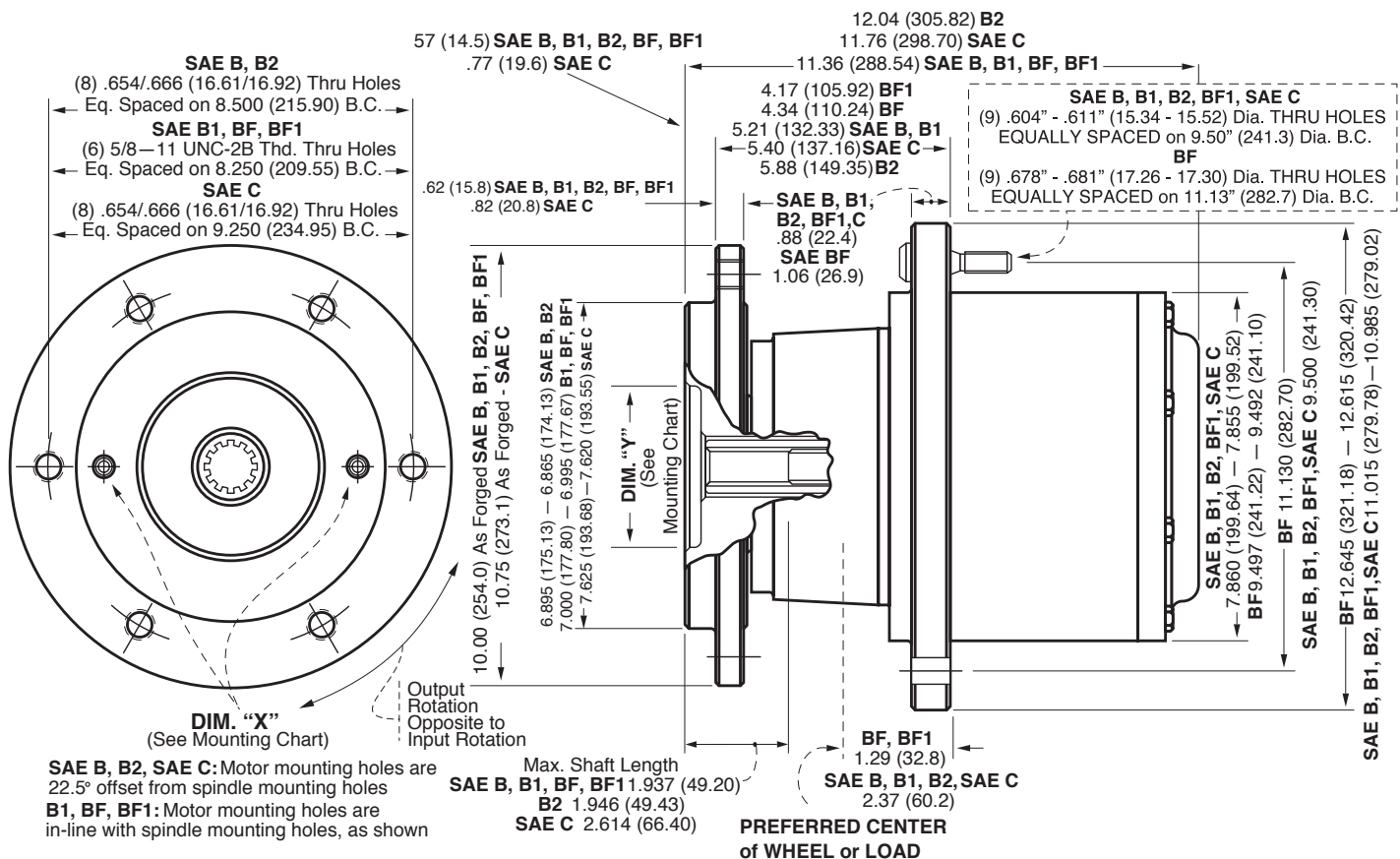

### Wheel Stud – Detail

Note that the stud lengths shown in the feature chart represent the total length of the stud under the head.

**NON-POWERED UNITS  
 ARE ALSO AVAILABLE  
 Contact Auburn Gear for Information**

## FEATURE CHART: MODEL 7 WHEEL DRIVES DOUBLE REDUCTION

OPTIONS	DESCRIPTION	MAKE ALL SELECTIONS WITHIN ONE COLUMN		ORDER CODES	USE OPTION ORDER CODES TO BUILD PART NUMBER			
MOTOR PILOT/HUB	SAE B	•		7WB	7WB			
	B1	•		7WB1				
	B2	•		7WB2				
	BF	•		7WBF				
	BF1	•		7WBF1				
	SAE C		•	7WC				
INPUT SPLINE	13T. <sup>16</sup> / <sub>32</sub>	•		13		13		
	14T. <sup>12</sup> / <sub>24</sub>		•	14				
	15T. <sup>16</sup> / <sub>32</sub>	•		15				
RATIO OPTIONS	13.06:1	•	•	13				
	15.88:1	•	•	15				
	17.94:1	•	•	17				
	19.62:1	•	•	19				
	21.74:1	•	•	21				
	24.53:1	•	•	24		24		
	28.37:1	•	•	28				
32.79:1	•	•	32					
WHEEL STUDS	<sup>1</sup> / <sub>2</sub> " by 1.89	•	•	15				
	<sup>1</sup> / <sub>2</sub> " by 2.50	•	•	16				
	<sup>9</sup> / <sub>16</sub> " by 2.06	•	•	17				
	<sup>9</sup> / <sub>16</sub> " by 2.75	•	•	18		18		
	<sup>5</sup> / <sub>8</sub> " by 2.37	•	•	8				
NONE	•	•	0					
SPECIAL FEATURES	Boot Seal	•	•	Z			Z	
	Quick Disconnect	•	•	Q				
	Oil Plugs/ Spindle Side	•	•	P				
	H.D. Multi-Lip Seal	•	•	T				
Select desired characteristics from chart, note correct order codes, and order using sample format shown at right:				7WB	13	24	18	Z

### MOTOR MOUNTING CHART

DIMENSION "X"	DIM. "Y"
SAE B, B1, B2, BF, BF1 (2)–.500 (12.70) -13 UNC. 2B Thd Holes Equally Spaced on 5.750 (146.05) B. C.*	ø 4.001 - 4.006 (101.62 - 101.75)
SAE C (4)– .500 (12.70) - 13 UNC. 2B Thd Holes Equally Spaced on 6.375 (161.93) B. C.*	ø 5.001 - 5.006 (127.02 - 127.15)

\* "O" RING OR GASKET REQUIRED (Not Supplied by Auburn Gear)  
"O" RING SIZES: SAE "B" 2–155, SAE "C" 2–159

#### NOTE:

The data presented in this catalog is for general information and preliminary layout purposes only. Auburn Gear, through its policy of continual improvement, reserves the right to update its products; therefore, the information presented is subject to change. For specific application and/or dimensional information, contact Auburn Gear.

MODEL 7 BEARING LIFE CURVE Based On  
LIFE = 3,000 Hours B10      SPEED = 100 RPM Output

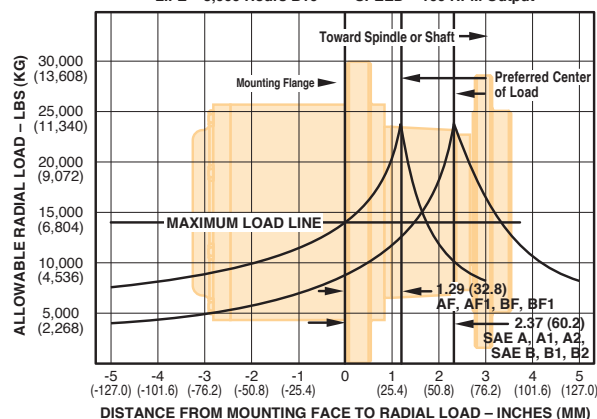

#### NOTE:

These curves are supplied as a design guide and apply to resultant radial load only. They indicate the importance of maintaining wheel position over the bearing center.

For actual analysis, applications should be reviewed by Auburn Gear Engineering using data supplied on Application Data Form.

### BEARING LOAD, LIFE AND SPEED RELATIONSHIPS

$$LF = \frac{SF \times R}{R'}$$

R = Allowable resultant load for given location from mounting flange

R' = Anticipated load at location from mounting flange

LF = Life Factor from table (see below)

SF = Speed Factor from table (see below)

OUTPUT SPEED (RPM)	SF	LF	BEARING HOURS B-10 LIFE
5	2.456	.584	500
10	1.994	.719	1000
20	1.620	.812	1500
30	1.435	.886	2000
40	1.316	.947	2500
50	1.231	1.000	3000
60	1.165	1.047	3500
70	1.113	1.090	4000
80	1.069	1.130	4500
90	1.032	1.166	5000
100	1.000	1.231	6000
200	.812	1.289	7000
300	.719	1.342	8000
400	.659	1.390	9000
500	.617	1.435	10000

**CAUTION:** The same torsional loading constraints used in the driving mode must be used in the braking mode when braking through the **Power Wheel** drive gear set.



## FEATURE CHART: MODEL 7 WHEEL DRIVES DOUBLE REDUCTION with BRAKE

OPTIONS	DESCRIPTION	MAKE ALL SELECTIONS WITHIN ONE COLUMN			ORDER CODES	USE OPTION ORDER CODES TO BUILD PART NUMBER					
MOTOR PILOT/HUB	SAE A	•	•		7WA						
	A1	•	•		7WA1						
	A2	•	•		7WA2						
	AF	•	•		7WAF						
	AF1	•	•		7WAF1						
	SAE B	•	•		7WB	7WB					
	B1	•	•		7WB1						
	B2	•	•		7WB2						
	BF	•	•		7WBF						
BF1	•	•		7WBF1							
INPUT SPLINE	13T. <sup>16</sup> / <sub>32</sub>	•			13						
	14T. <sup>12</sup> / <sub>24</sub>		•	•	14						
	15T. <sup>16</sup> / <sub>32</sub>			•	15	15					
RATIO OPTIONS	13.06:1	•	•	•	13						
	15.88:1	•	•	•	15						
	17.94:1	•	•	•	17						
	19.62:1	•	•	•	19						
	21.74:1	•	•	•	21						
	24.53:1	•	•	•	24		24				
	28.37:1	•	•	•	28						
32.79:1	•	•	•	32							
WHEEL STUDS	<sup>1</sup> / <sub>2</sub> " by 1.89	•	•	•	15						
	<sup>1</sup> / <sub>2</sub> " by 2.50	•	•	•	16						
	<sup>9</sup> / <sub>16</sub> " by 2.06	•	•	•	17						
	<sup>9</sup> / <sub>16</sub> " by 2.75	•	•	•	18			18			
	<sup>5</sup> / <sub>8</sub> " by 2.37	•	•	•	8						
	NONE	•	•	•	0						
PARKING BRAKE	1,540 lb-in			•	B1						
	1,800 lb-in	•	•	•	B2						
	2,400 lb-in	•	•	•	B3						
	2,400 lb-in	•	•	•	B4				B4		
	3,200 lb-in	•	•	•	B5						
	3,600 lb-in	•	•	•	B6						
	4,200 lb-in	•	•	•	B7						
SPECIAL FEATURES	Boot Seal	•	•	•	Z					Z	
	Quick Disconnect	•	•	•	Q						
	Oil Plugs/ Spindle Side	•	•	•	P						
	H.D. Multi-Lip Seal	•	•	•	T						
							7WB	15	24	18	B4

Select desired characteristics from chart, note correct order codes, and order using sample format shown at right:

### MOTOR MOUNTING CHART

DIMENSION "X"	DIM. "Y"
SAE A, A1, A2, AF, AF1 (2)–.325 (12.70) -16 UNC, -2B Thd Holes Equally Spaced on 4.188 (106.38) B. C.* AND (4)–.500 (12.70) -13 UNC, -2B Thd Holes on 4.188 (106.38) B.C.*	ø 3.251 - 3.256 (82.58 - 82.70)
SAE B, B1, B2, BF, BF1 (2)–.500 (12.70) - 13 UNC, -2B Thd Holes Equally Spaced on 5.750 (146.05) B. C.*	ø 4.001 - 4.006 (101.62 - 101.75)

\*"O" RING OR GASKET REQUIRED (Not Supplied by Auburn Gear)  
"O" RING SIZES: SAE "B" 2-155, SAE "C" 2-159

MODEL 7 BEARING LIFE CURVE Based On  
LIFE = 3,000 Hours B10      SPEED = 100 RPM Output

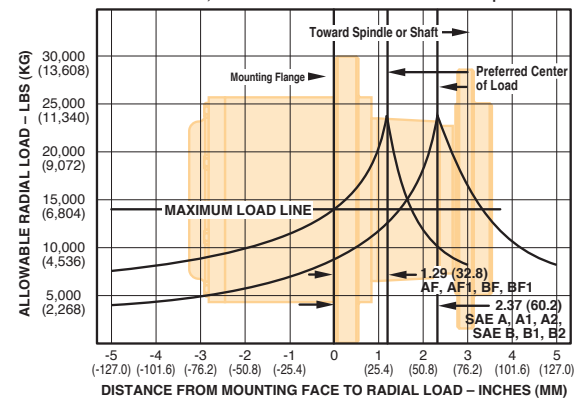

**NOTE:**

These curves are supplied as a design guide and apply to resultant radial load only. They indicate the importance of maintaining wheel position over the bearing center.

For actual analysis, applications should be reviewed by Auburn Gear Engineering using data supplied on Application Data Form.

### BEARING LOAD, LIFE AND SPEED RELATIONSHIPS

$$LF = \frac{SF \times R}{R'}$$

R = Allowable resultant load for given location from mounting flange

R' = Anticipated load at location from mounting flange

LF = Life Factor from table (see below)

SF = Speed Factor from table (see below)

OUTPUT SPEED (RPM)	SF	LF	BEARING HOURS B-10 LIFE
5	2.456	.584	500
10	1.994	.719	1000
20	1.620	.812	1500
30	1.435	.886	2000
40	1.316	.947	2500
50	1.231	1.000	3000
60	1.165	1.047	3500
70	1.113	1.090	4000
80	1.069	1.130	4500
90	1.032	1.166	5000
100	1.000	1.231	6000
200	.812	1.289	7000
300	.719	1.342	8000
400	.659	1.390	9000
500	.617	1.435	10000

**CAUTION:** The same torsional loading constraints used in the driving mode must be used in the braking mode when braking through the **Power Wheel** drive gear set.

**NOTE:**

The data presented in this catalog is for general information and preliminary layout purposes only. Auburn Gear, through its policy of continual improvement, reserves the right to update its products; therefore, the information presented is subject to change. For specific application and/or dimensional information, contact Auburn Gear.



# Model 7 Shaft & Spindle Output Drives Single & Double Reduction

## General Specifications

Single Reduction	Double Reduction
Max. intermittent output torque <sup>1</sup> .....42,000 lb-in (4,745 Nm)	Max. intermittent output torque <sup>1</sup> .....70,000 lb-in (7,910 Nm)
Max. input speed.....3,500 RPM	Max. input speed .....5,000 RPM
Approximate Weight ..... 77 lbs (34.9kg)	Approximate Weight ..... 99 lbs (44.9kg)
Approximate Oil capacity..... 21 oz (621 cc)	Approximate Oil capacity..... 30 oz (887 cc)

For Lubrication Data, see Page 15

<sup>1</sup>Depending on the duty cycle and the nature of the application, a normal continuous output torque of 1/3 to 1/2 of the maximum Intermittent should yield satisfactory Power Wheel® life. Also, due to the Model 7's unique combination of small physical size and high torque potential, thermal capacity may become limiting factor.

Customer testing and application analysis is strongly recommended.

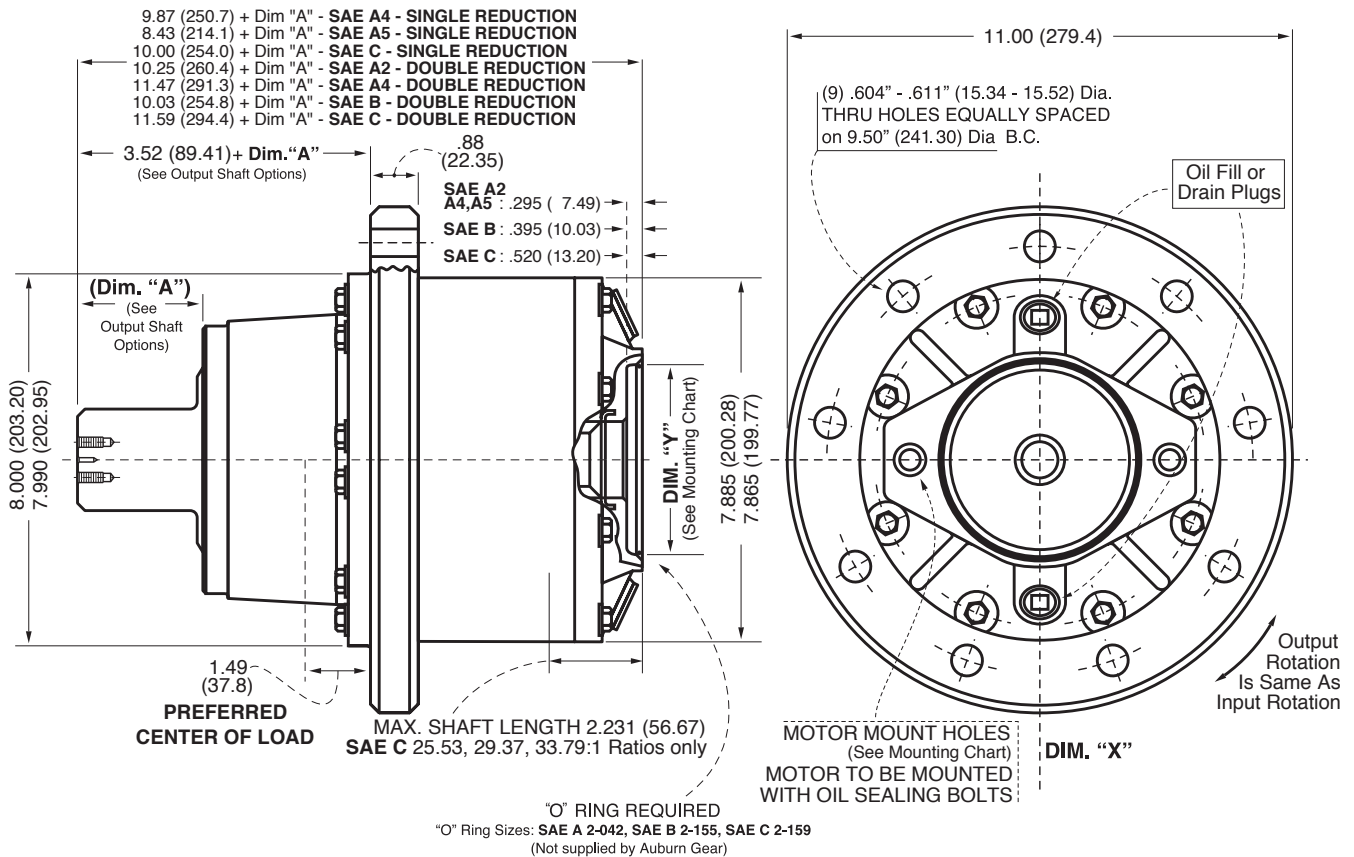

MOTOR MOUNTING CHART	
DIMENSION "X"	DIM. "Y"
SAE A2: (2) - .500 (12.70) - 13 UNC - 2B Thd Holes on 4.188 (106.38) B.C.*	ø 3.251 - 3.256 (82.58 - 82.70)
SAE A4, A5: (4) - .500 (12.70) - 13 UNC - 2B Thd Holes on 4.188 (106.38) B.C. ^	ø 3.251 - 3.256 (82.58 - 82.70)
SAE B: (2) - .500 (12.70) - 13 UNC - 2B Thd Holes on 5.750 (146.05) B.C.*	ø 4.001 - 4.006 (101,62 - 101,75)
SAE C: (2) - .625 (15.87) - 11 UNC - 2B Thd Holes Equally Spaced on 7.125 (180.97) B.C. AND (4) - .500 (12.70) - 13 UNC - 2B Thd Holes Equally Spaced on 6.375 (161.93) B.C.*	ø 5.001 - 5.006 (127.02 - 127.15)

**NOTE:**  
 The data presented in this catalog is for general information and preliminary layout purposes only. Auburn Gear, through its policy of continual improvement, reserves the right to update its products; therefore, the information presented is subject to change. For specific application and/or dimensional information, contact Auburn Gear.

\* "O" RING OR GASKET REQUIRED (Not Supplied by Auburn Gear)  
 "O" RING SIZES: SAE "A" 2-042, SAE "B" 2-155, SAE "C" 2-159

# FEATURE CHART: MODEL 7 SHAFT & SPINDLE OUTPUT DRIVES SINGLE & DOUBLE REDUCTION

OPTIONS	DESCRIPTION	MAKE ALL SELECTIONS WITHIN ONE COLUMN				ORDER CODES	USE OPTION ORDER CODES TO BUILD PART NUMBER			
MOTOR PILOT/HUB	SAE A2	•				7SA2				
	A4	•				7SA4				
	A4				•	7TA4				
	A5				•	7TA5				
	SAE B		•			7SB	7SB			
	SAE C			•		7SC				
INPUT SPLINE	13T - 16/32	•	•			13		13		
	14T - 12/24	•	•	•		14				
RATIO OPTIONS	SINGLE	3.75:1				•	03			
		4.50:1				•	04			
		5.81:1				•	06			
	DOUBLE	14.06:1 ^	•	•	•		14			
		16.88:1 ^	•	•	•		16			
		18.94:1 ^	•	•	•		18			
		20.62:1 ^	•	•	•		20		20	
		22.74:1 ^	•	•	•		22			
		25.53:1 *	•	•	•		25			
		29.37:1 *	•	•	•		29			
33.79:1 *	•	•	•		33					
OUTPUT SHAFTS and SPINDLES (See Chart - pg. 14)	20T - 8/16 w/axial center hole	•	•	•	•	20				
	23T - 8/16	•	•	•	•	23L				
	2" Hex w/ thru hole	•	•	•	•	H1				
	3" Dia w/ keyway	•	•	•	•	K2			K2	
	3" Dia w/2 keyways	•	•	•	•	K3				
	2.557" Dia w/keyway	•	•	•	•	K4				
	Spindle	•	•	•	•	F1				
	Spindle	•	•	•	•	F2				
Bolts in Spindle	9/16"-18UNF x 2.75"	•	•	•	•	7				7
	None	•	•	•	•	00				
SPECIAL FEATURES	Oil Plug on output side of hub	•	•	•	•	P				P
	H.D. Multi-Lip Seal	•	•	•	•	T				

Select desired characteristics from chart, note correct order codes, and order using sample format shown at right: 7SB 13 20 K2 7 P

^ Motor spacer is required when these ratios are used with ANY SAE 'A' mount and 14T input spline  
 \*These ratios are NOT available with 7SA2 motor pilot & 14T input

MODEL 7 BEARING LIFE CURVE Based On  
 LIFE = 3,000 Hours B10 SPEED = 100 RPM Output

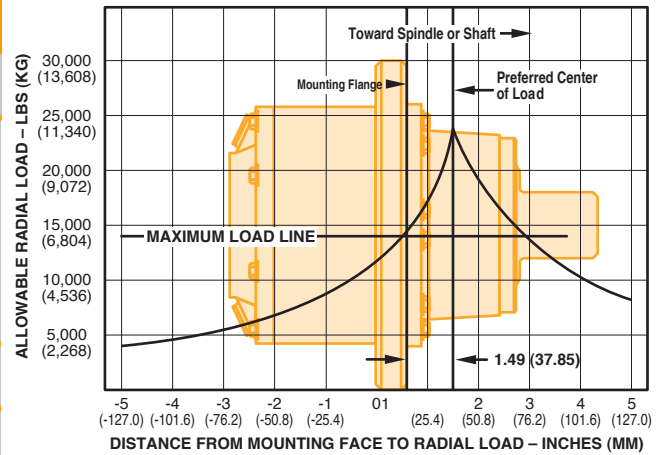

**NOTE:**

These curves are supplied as a design guide and apply to resultant radial load only. They indicate the importance of maintaining wheel position over the bearing center.

For actual analysis, applications should be reviewed by Auburn Gear Engineering using data supplied on Application Data Form.

**BEARING LOAD, LIFE AND SPEED RELATIONSHIPS**

$$LF = \frac{SF \times R}{R'}$$

- R = Allowable resultant load for given location from mounting flange
- R' = Anticipated load at location from mounting flange
- LF = Life Factor from table (see below)
- SF = Speed Factor from table (see below)

OUTPUT SPEED (RPM)	SF	LF	BEARING HOURS B-10 LIFE
5	2.456	.584	500
10	1.994	.719	1000
20	1.620	.812	1500
30	1.435	.886	2000
40	1.316	.947	2500
50	1.231	1.000	3000
60	1.165	1.047	3500
70	1.113	1.090	4000
80	1.069	1.130	4500
90	1.032	1.166	5000
100	1.000	1.231	6000
200	.812	1.289	7000
300	.719	1.342	8000
400	.659	1.390	9000
500	.617	1.435	10000

**CAUTION:** The same torsional loading constraints used in the driving mode must be used in the braking mode when braking through the **Power Wheel** drive gear set.

# Power Wheel®

## Model 7 Shaft & Spindle Output Drives

### Double Reduction with A2 Series Integral Parking Brake

#### General Specifications

Max. intermittent output torque <sup>1</sup> .....70,000 lb-in (7,910 Nm)	Approximate Weight ..... 137 lbs (62kg)
Max. input speed <sup>2</sup> .....3,500 RPM	Approximate Oil capacity..... 42 oz (920 cc)

*For Lubrication Data, see Page 15*

<sup>1</sup> Depending on the duty cycle and the nature of the application, a normal continuous output torque of 1/3 to 1/2 of the maximum Intermittent should yield satisfactory Power Wheel® life. Also, due to the Model 7's unique combination of small physical size and high torque potential, thermal capacity may become limiting factor.

<sup>2</sup> For input speed in excess of 3,500 rpm please contact Auburn Gear for duty cycle analysis.

Customer testing and application analysis is strongly recommended.

*For General Brake Data, See Page 3*

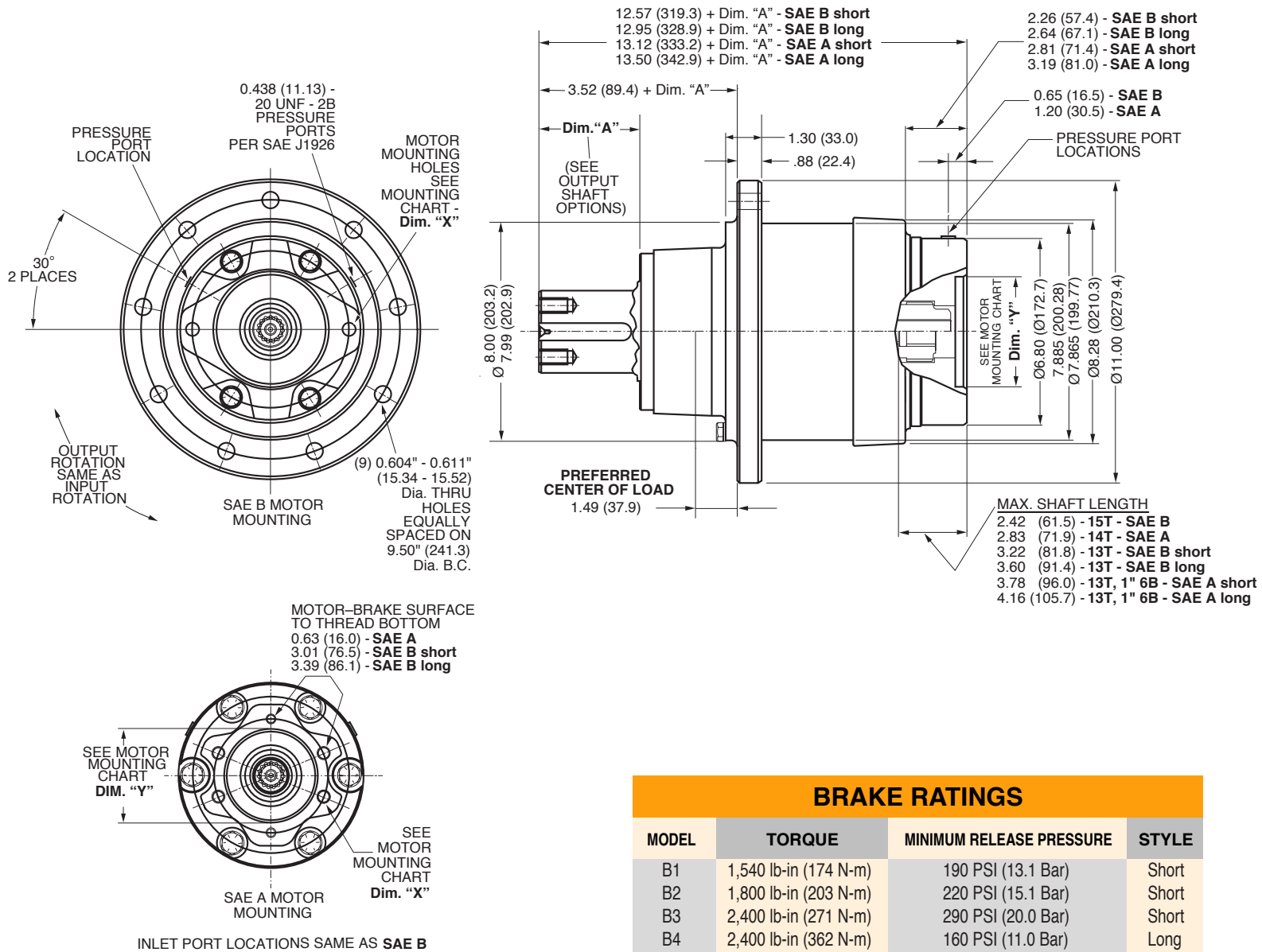

#### BRAKE RATINGS

MODEL	TORQUE	MINIMUM RELEASE PRESSURE	STYLE
B1	1,540 lb-in (174 N-m)	190 PSI (13.1 Bar)	Short
B2	1,800 lb-in (203 N-m)	220 PSI (15.1 Bar)	Short
B3	2,400 lb-in (271 N-m)	290 PSI (20.0 Bar)	Short
B4	2,400 lb-in (362 N-m)	160 PSI (11.0 Bar)	Long
B5	3,200 lb-in (362 N-m)	220 PSI (15.1 Bar)	Long
B6	3,600 lb-in (407 N-m)	230 PSI (15.8 Bar)	Long
B7	4,200 lb-in (475 N-m)	260 PSI (17.9 Bar)	Long

Maximum Release Pressure = 3,000 PSI (206.4 Bar)

# FEATURE CHART: MODEL 7 SHAFT & SPINDLE OUTPUT DRIVES DOUBLE REDUCTION with BRAKE

OPTIONS	DESCRIPTION	MAKE ALL SELECTIONS WITHIN ONE COLUMN		ORDER CODES	USE OPTION ORDER CODES TO BUILD PART NUMBER				
MOTOR PILOT/HUB	SAE A	•		7SA					
	SAE B		•	7SB	7SB				
INPUT SPLINE	13T. <sup>16</sup> / <sub>32</sub> "	•	•	13		13			
	14T. <sup>12</sup> / <sub>24</sub> "	•		14					
	15T. - <sup>16</sup> / <sub>32</sub> "	•		15					
	1" - 6B	•		6B					
RATIO OPTIONS	14.06:1	•	•	14					
	16.88:1	•	•	16					
	18.94:1	•	•	18					
	20.62:1	•	•	20		20			
	22.74:1	•	•	25					
	25.53:1	•	•	25					
	29.37:1	•	•	29					
33.79:1	•	•	33						
OUTPUT SHAFTS and SPINDLES (See Chart - pg. 14)	20T - 8/16 w/axial center hole	•	•	20					
	23T - 8/16	•	•	23L					
	2" Hex w/ thru hole	•	•	H1					
	3" Dia w/ keyway	•	•	K2					
	3" Dia w/2 keyways	•	•	K3					
	2.557" Dia w/keyway	•	•	K4			K4		
	Spindle	•	•	F1					
	Spindle	•	•	F2					
SHORT VERSION	1,540 lb-in	•	•	B1					
	1,800 lb-in	•	•	B2					
PARKING BRAKE	2,400 lb-in	•	•	B3					
	2,400 lb-in	•	•	B4				B4	
LONG VERSION	3,200 lb-in	•	•	B5					
	3,600 lb-in	•	•	B6					
	4,200 lb-in	•	•	B7					
SPECIAL FEATURES	BOOT SEAL	•	•	Z					Z
	H.D. Multi-Lip Seal	•	•	T					

Select desired characteristics from chart, note correct order codes, and order using sample format shown at right:

7SB 13 20 K4 B4 Z

## MOTOR MOUNTING CHART

DIMENSION "X"	DIM. "Y"
SAE A (2)– .375 (12.70) -16 UNC, -2B Thd Holes Equally Spaced on 4.188 (106.38) B. C.* AND (4)– .500 (12.70) -13 UNC, -2B Thd Holes on 4.188 (106.38) B. C.*	ø 3.251 - 3.256 (82.58 - 82.70)
SAE B (4)– .500 (12.70) - 13 UNC, - 2B Thd Holes Equally Spaced on 5.750 (146.05) B. C.*	ø 4.001 - 4.006 (101.62 - 101.75)

\* "O" RING OR GASKET REQUIRED (Not Supplied by Auburn Gear)  
"O" RING SIZES: SAE "B" 2-155, SAE "C" 2-159

MODEL 7 BEARING LIFE CURVE Based On  
LIFE = 3,000 Hours B10 SPEED = 100 RPM Output

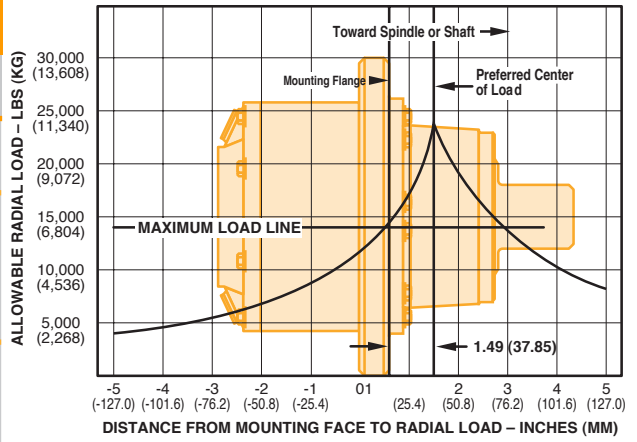

### NOTE:

These curves are supplied as a design guide and apply to resultant radial load only. They indicate the importance of maintaining wheel position over the bearing center.

For actual analysis, applications should be reviewed by Auburn Gear Engineering using data supplied on Application Data Form.

## BEARING LOAD, LIFE AND SPEED RELATIONSHIPS

$$LF = \frac{SF \times R}{R'}$$

R = Allowable resultant load for given location from mounting flange

R' = Anticipated load at location from mounting flange

LF = Life Factor from table (see below)

SF = Speed Factor from table (see below)

OUTPUT SPEED (RPM)	SF	LF	BEARING HOURS B-10 LIFE
5	2.456	.584	500
10	1.994	.719	1000
20	1.620	.812	1500
30	1.435	.886	2000
40	1.316	.947	2500
50	1.231	1.000	3000
60	1.165	1.047	3500
70	1.113	1.090	4000
80	1.069	1.130	4500
90	1.032	1.166	5000
100	1.000	1.231	6000
200	.812	1.289	7000
300	.719	1.342	8000
400	.659	1.390	9000
500	.617	1.435	10000

CAUTION: The same torsional loading constraints used in the driving mode must be used in the braking mode when braking through the Power Wheel drive gear set.

### NOTE:

The data presented in this catalog is for general information and preliminary layout purposes only. Auburn Gear, through its policy of continual improvement, reserves the right to update its products; therefore, the information presented is subject to change. For specific application and/or dimensional information, contact Auburn Gear.





## FEATURE CHART: MODEL 7 SHAFT INPUT/OUTPUT DRIVES DOUBLE REDUCTION

OPTIONS	DESCRIPTION	MAKE ALL SELECTIONS WITHIN ONE COLUMN	ORDER CODES	USE OPTION ORDER CODES TO BUILD PART NUMBER			
HUB	STD Model 7 Shaft Output Double Reduction	•	7S	7S			
INPUT SHAFT	1 1/2" Keyed	•	K00		K00		
RATIO OPTIONS	14.06:1	•	14				
	16.88:1	•	16				
	18.94:1	•	18				
	20.62:1	•	20				
	22.74:1	•	22				
	25.53:1	•	25			25	
	29.37:1	•	29				
	33.79:1	•	33				
OUTPUT SHAFTS	3.0" KEYED	•	K2			K2	
<small>Select desired characteristics from chart, note correct order codes, and order using sample format shown at right:</small>				7S	K00	25	K2

MODEL 7 BEARING LIFE CURVE Based On  
LIFE = 3,000 Hours B10      SPEED = 100 RPM Output

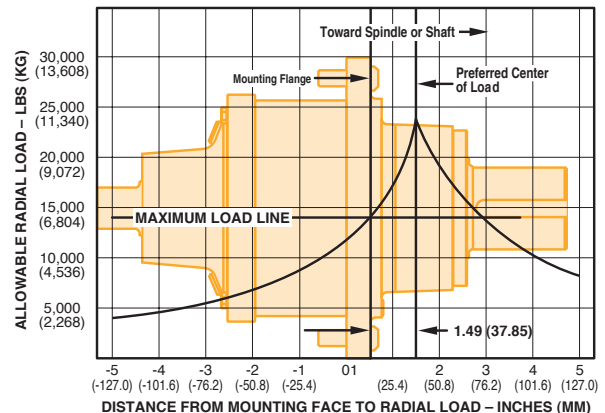

**NOTE:**  
 These curves are supplied as a design guide and apply to resultant radial load only. They indicate the importance of maintaining wheel position over the bearing center.  
 For actual analysis, applications should be reviewed by Auburn Gear Engineering using data supplied on Application Data Form.

### BEARING LOAD, LIFE AND SPEED RELATIONSHIPS

$$LF = \frac{SF \times R}{R'}$$

- R = Allowable resultant load for given location from mounting flange
- R' = Anticipated load at location from mounting flange
- LF = Life Factor from table (see below)
- SF = Speed Factor from table (see below)

OUTPUT SPEED (RPM)	SF	LF	BEARING HOURS B-10 LIFE
5	2.456	.584	500
10	1.994	.719	1000
20	1.620	.812	1500
30	1.435	.886	2000
40	1.316	.947	2500
50	1.231	1.000	3000
60	1.165	1.047	3500
70	1.113	1.090	4000
80	1.069	1.130	4500
90	1.032	1.166	5000
100	1.000	1.231	6000
200	.812	1.289	7000
300	.719	1.342	8000
400	.659	1.390	9000
500	.617	1.435	10000

**CAUTION:** The same torsional loading constraints used in the driving mode must be used in the braking mode when braking through the **Power Wheel** drive gear set.

**NOTE:**  
 The data presented in this catalog is for general information and preliminary layout purposes only. Auburn Gear, through its policy of continual improvement, reserves the right to update its products; therefore, the information presented is subject to change. For specific application and/or dimensional information, contact Auburn Gear.

# OUTPUT SHAFT OPTIONS

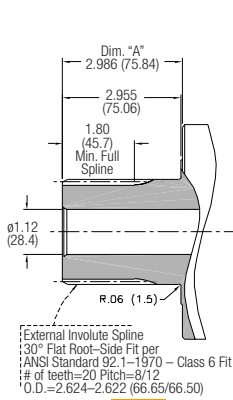

**20**

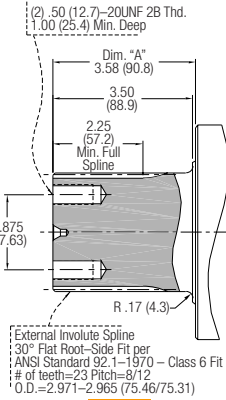

**23L**

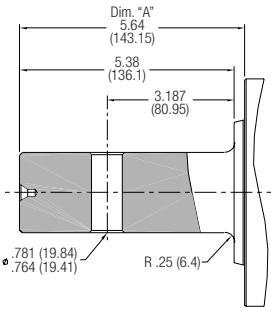

**H1**

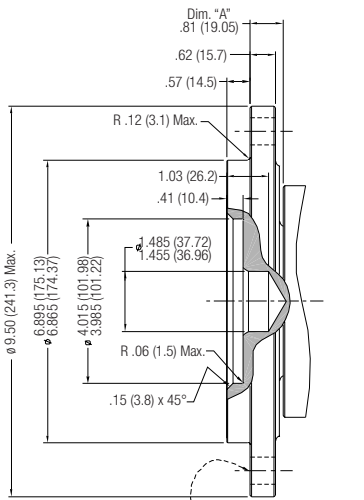

**F1**

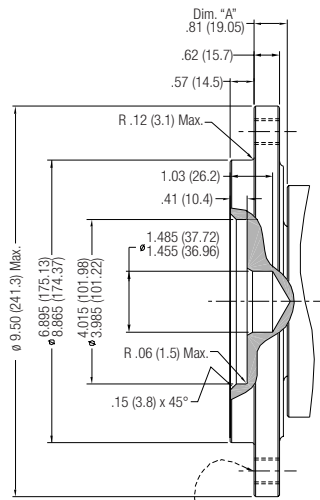

**F2**

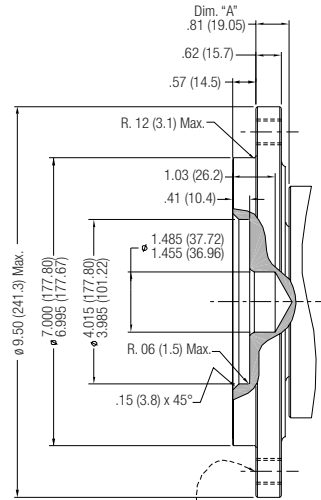

**F6**

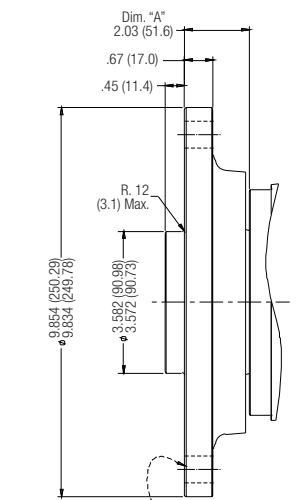

**F7**

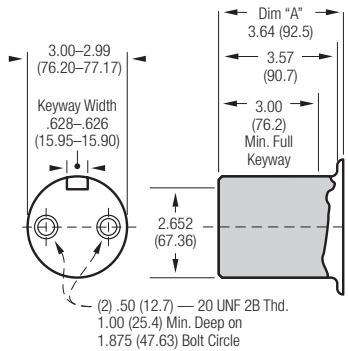

**K2**

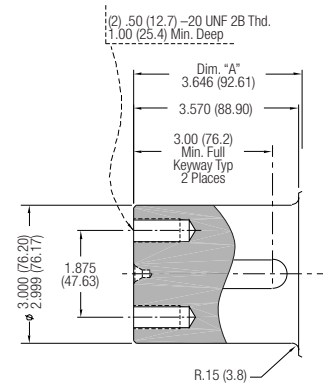
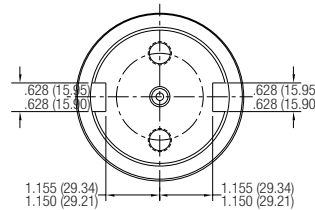

**K3**

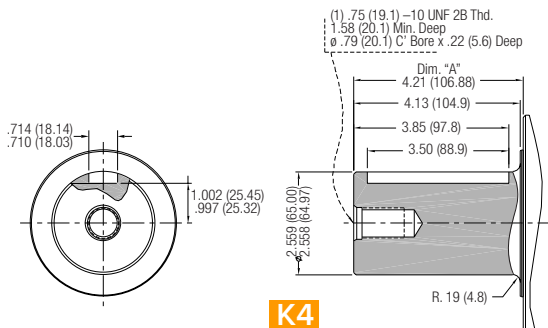

**K4**

## OTHER OPTIONS

### Boot Seal

An optional seal that protects the main oil seal from dirt and other debris. The boot seal will give extended life on applications operating in extremely muddy or dirty conditions. Boot seals are available on a selective model basis.

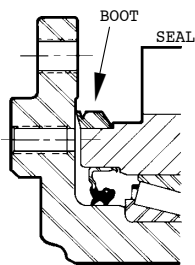

### Weldable Hub

The hubs are 4140H steel and can be turned down and/or welded for mounting sprockets, pulleys, or other devices. A circular keeper plate secures the hub to the splined output shaft with two bolts (keeper plate and bolts included.)

KIT NUMBER	SPLINE	FITS MODELS
6420105	23T- <sup>12</sup> / <sub>24</sub>	5, 6, & 8
6420106	23T- <sup>8</sup> / <sub>16</sub>	7, 8, 9, & 10
6420107	20T- <sup>8</sup> / <sub>16</sub>	8, & 9

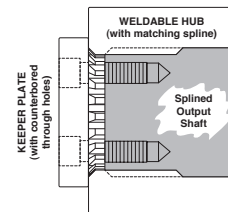

### Quick Disconnect

This optional disconnect is available on all wheel drives. No tools are needed to disengage the drive. The planetary drive is disengaged with the push of a button. The quick disconnect eliminates removal of the disconnect cover and external contaminants are sealed from the units by internal O-rings and a gasket that is sandwiched between the disconnect and planetary cover. The rugged, compact design ensures dependable service.

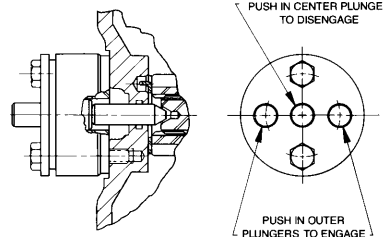

## LUBRICATION DATA

**POWER WHEEL PLANETARY DRIVES ARE SHIPPED WITHOUT LUBRICANT AND MUST BE FILLED TO THE PROPER LEVEL PRIOR TO START-UP**

#### 1. Type

In normal application use an extreme pressure lubricant API-GL-5 approved. AGI recommends SAE 80W, 90, 80W-90 and 85W-90 grades of lube under normal climate and operating conditions. See chart below. For severe or abnormal applications with special requirements consult either Auburn Gear or a lubricant manufacturer for further assistance.

#### 2. Change Interval

Initial lubrication change after 50 hours of operation. Subsequent changes every 1000 hours or yearly whichever occurs first.

#### 3. Lube Temperature

Continuous operating temperatures of 160°F are allowable. Maximum intermittent temperature recommended is 200°F.

#### 4. Amount of Lube

The unit should be half full when mounted horizontal. Lube levels for other mounts will vary. Consult Auburn Gear for details.

#### 5. Shaft or Spindle Up Mounting

If mounting unit vertically with shaft or spindle up, special provisions apply to ensure adequate lubrication of output bearings. Consult Auburn Gear.

AUBURN GEAR POWER WHEEL LOW TEMPERATURE GEAR LUBE REQUIREMENT	
SAE VISCOSITY GRADE	AUBURN GEAR RECOMMENDED MINIMUM TEMPERATURE
75W-90	-40°F (-40°C)*
80W, 80W-90	-15°F (-26°C)*
85W, 85W-90	10°F (-12°C)*
90	35°F (2°C)

\* Maximum temperature for Brookfield Viscosity<sup>1</sup> of 150,000 centipoise of (cP)<sup>2</sup> per SAE J306 MAR85

<sup>1</sup> Brookfield Viscosity - apparent viscosity as determined under ASTM D 2983

<sup>2</sup> 150,000 cP determined to provide sufficient low temperature lube properties for Auburn Gear Power Wheels

**All Power Wheels® are compatible with synthetic lubricants as long as they meet the above specified parameters.**

## Power Wheel® Warranty

Seller warrants to Purchaser that its Power Wheel® planetary gear products are free from defects in material and workmanship under normal use and service for a period of one year from the date the product is shown to have been placed into operation by original user or for two years from date of shipment from seller's plant, whichever shall first occur.

Seller's obligation under this warranty is expressly limited to the repair or replacement at its option, of the Power Wheel which is returned with a written claim of defect f.o.b. seller's factory, Auburn, Indiana, U.S.A., and which is determined by Seller to be defective in fact.

THIS IS THE SOLE AND ONLY WARRANTY OF SELLER AND NO OTHER WARRANTY IS APPLICABLE EITHER EXPRESSED OR IMPLIED, IN FACT OR BY LAW, INCLUDING ANY WARRANTY AS TO MERCHANTABILITY OF FITNESS FOR A PARTICULAR USE OR PURPOSE.

The sole and only remedy in regard to any defective Power Wheel shall be the repair or replacement thereof herein provided, and seller shall not be liable for any consequential, special, incidental, or punitive damages, losses or expenses resulting from or caused by any defects.

AUBURN GEAR, INC.

AUBURN, INDIANA, U.S.A.





# Power Wheel® Model 7 Planetary Gear Drives





Our international sales network covers every jurisdiction. Our global shipping partners mean you can be sure we're on hand whenever you need us.

## **Zeus Hydratech Ltd**

Unit 35  
Old Mills Industrial Estate  
Paulton  
Bristol, BS39 7SU  
United Kingdom

T. +44 (0) 1172 130042  
E: [info@zeushydratech.com](mailto:info@zeushydratech.com)  
W. [www.zeushydratech.com](http://www.zeushydratech.com)