



DZC*

BALANCING VALVE

SERIES 10

DZC5 **CETOP P05**
DZC5R **ISO 4401-05 (CETOP R05)**
DZC7 **ISO 4401-07 (CETOP 07)**
DZC8 **ISO 4401-08 (CETOP 08)**

p max **350** bar
Q max (see table of performances)

OPERATING PRINCIPLE

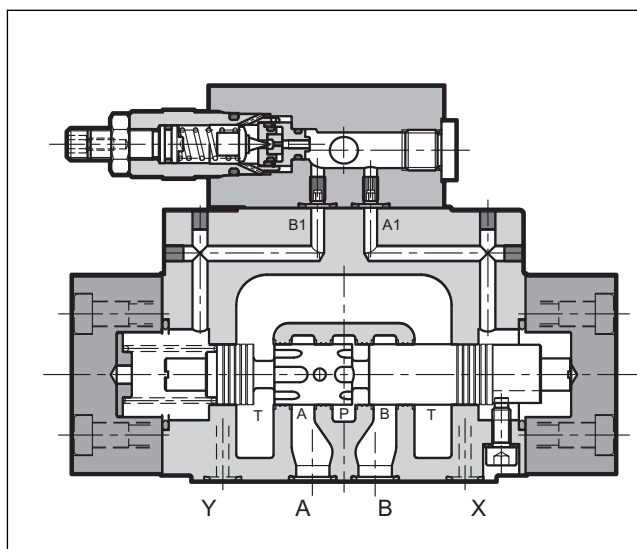

- The type DZC* balancing valves act as pressure reducing valves that, besides reducing the pressure from line P to user A, allow the flow to return from user A to discharge T when a pressure greater than the set value is generated in the downstream circuit (user A) (a typical case of hydraulic counterweight or load balancing)
- They have a mounting surface in accordance with ISO 4401 (CETOP RP121H) standards. Port B is never used.
- They are available in three different sizes for flow rates up to 500 l/min.

PERFORMANCES (obtained with mineral oil with viscosity of 36 cSt at 50°C)

		DZC5 DZC5R	DZC7	DZC8
Maximum operating pressure:	bar	350		
Maximum flow	l/min	150	300	500
Ambient temperature range	°C	-20 / +50		
Fluid temperature range	°C	-20 / +80		
Fluid viscosity range	cSt	10 + 400		
Fluid contamination degree	According to ISO 4406:1999 class 20/18/15			
Recommended viscosity	cSt	25		
Mass:	kg	6,5	8,7	15

HYDRAULIC SYMBOL

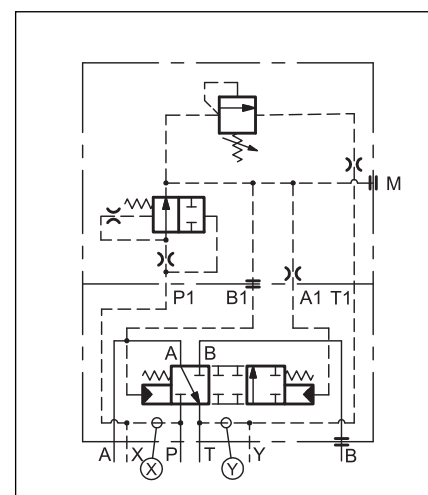

1 - IDENTIFICATION CODE

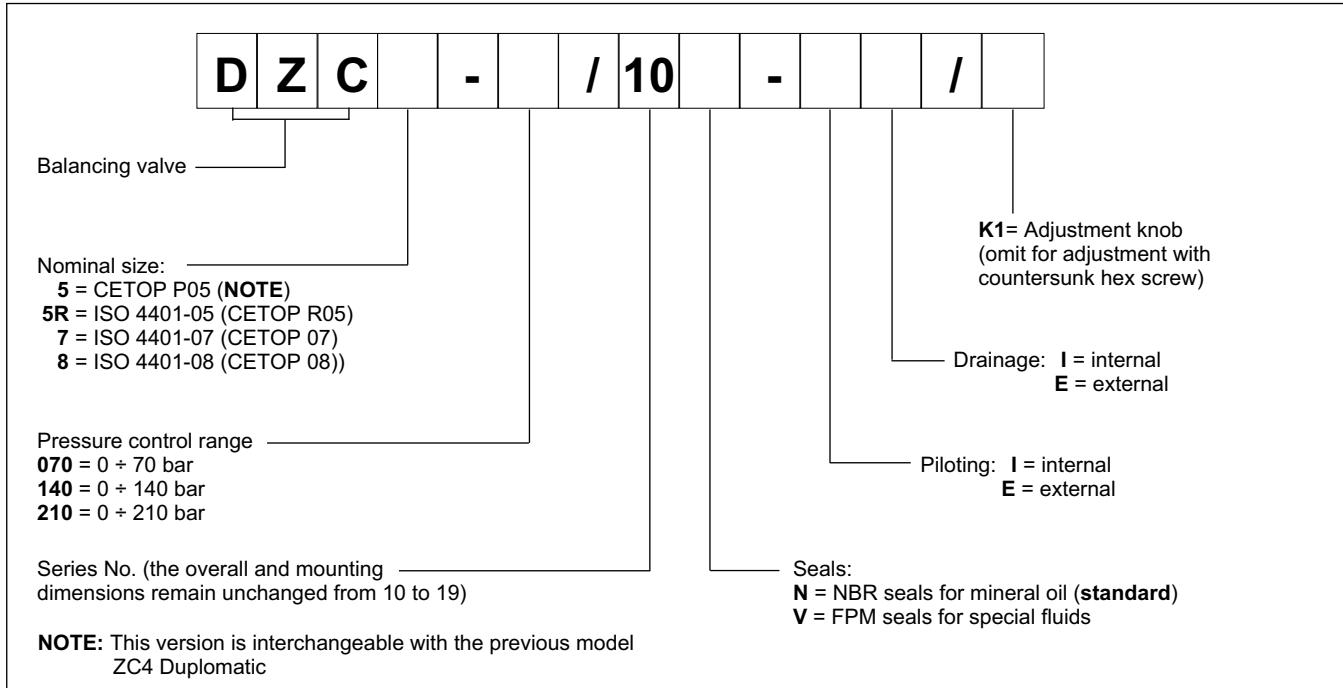

3 - CHARACTERISTIC CURVES (obtained with mineral oil with viscosity of 36 cSt at 50°C and electronic control cards)

2.1 - Characteristic curves DZC5 and DZC5R

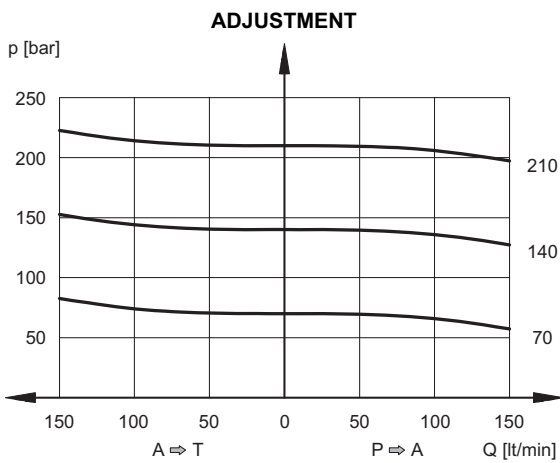

2.2 - Characteristic curves DZC7

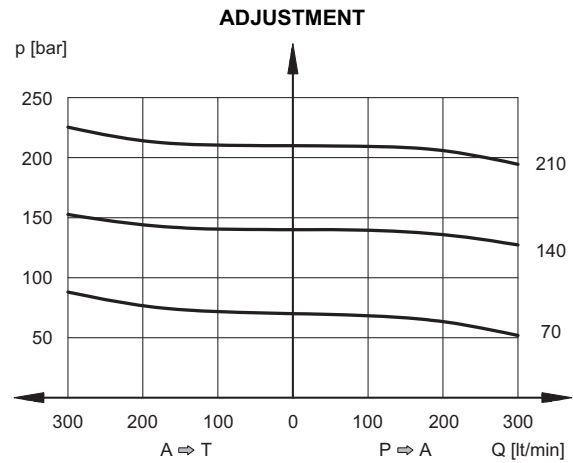

2.3 - Characteristic curves DZC8

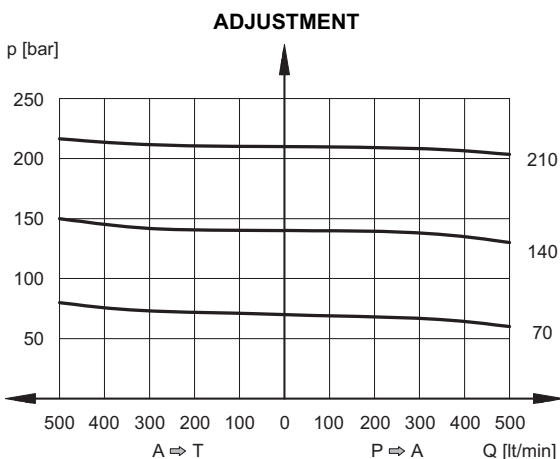

3 - HYDRAULIC FLUIDS

Use mineral oil-based hydraulic fluids HL or HM type, according to ISO 6743-4. For these fluids, use NBR seals (code N). For fluids HFDR type (phosphate esters) use FPM seals (code V). For the use of other kinds of fluid such as HFA, HFB, HFC, please consult our technical department. Using fluids at temperatures higher than 80 °C causes a faster degradation of the fluid and of the seals characteristics. The fluid must be preserved in its physical and chemical characteristics.

4 - PILOTING AND DRAINAGE

The DZC* valves are available with piloting and drainage, both internal and external. We suggest to use the version with external drainage that allows a higher backpressure on the unloading.

VALVE TYPE	Plug assembly	
	X	Y
IE INTERNAL PILOT AND EXTERNAL DRAIN	NO	YES
II INTERNAL PILOT AND INTERNAL DRAIN	NO	NO
EE EXTERNAL PILOT AND EXTERNAL DRAIN	YES	YES
EI EXTERNAL PILOT AND INTERNAL DRAIN	YES	NO

PRESSURES (bar)

Pressure	MIN	MAX
Piloting pressure on X port	30	210
Pressure on T port with internal drain	–	2
Pressure on T port with external drain	–	250

DZC5 and DZC5R

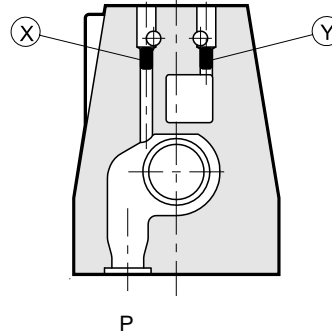

X: M5x6 plug for external pilot
Y: M5x6 plug for external drain

P

DZC7

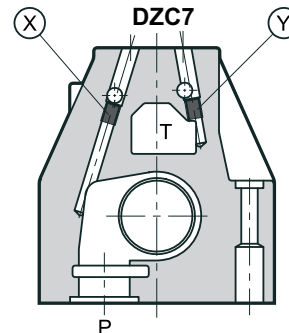

X: M6x8 plug for external pilot
Y: M6x8 plug for external drain

P

DZC8

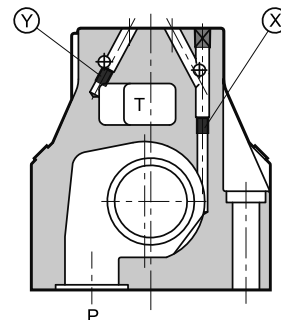

X: M6x8 plug for external pilot
Y: M6x8 plug for external drain

P

5 - INSTALLATION

The DZC* valves can be installed in any position without impairing correct operation.

Connect the valve T port directly to the tank. Add any backpressure value detected in the T line to the controlled pressure value. Maximum admissible backpressure in the T line, under operational conditions, is 2 bar. Valves are fixed by means of screws or tie rods on a flat surface with planarity and roughness equal to or better than those indicated in the relative symbols. If minimum values are not observed, fluid can easily leak between the valve and support surface.

surface finishing

0.01/100

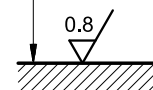

6 - DZC5 AND DZC5R OVERALL AND MOUNTING DIMENSIONS

dimensions in mm

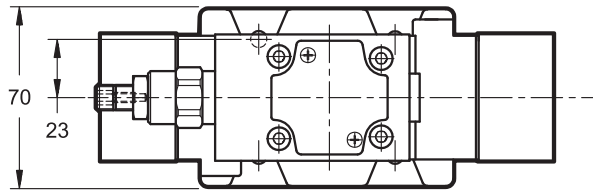
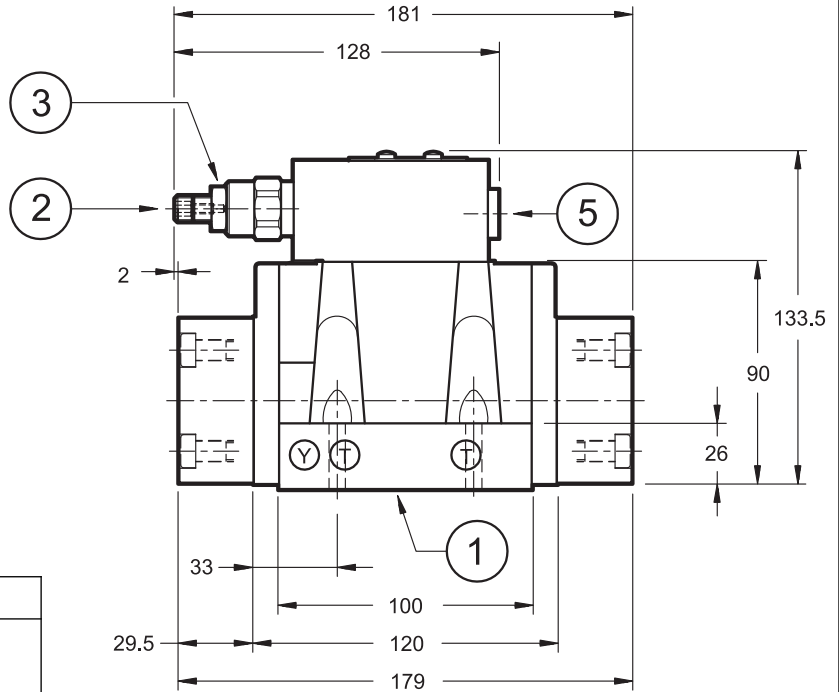
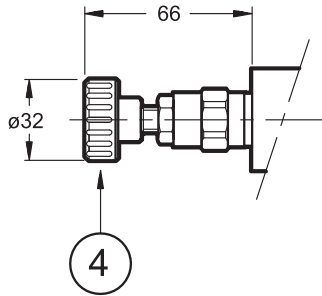

1	Mounting surface with sealing rings
2	Countersunk hex adjustment screw: Spanner 5. Clockwise rotation to increase pressure
3	Locking nut: spanner 17
4	Adjustment knob: M1
5	Pressure gauge port 1/4" BSP

Valve fastening: N. 4 bolts SHC ISO 4762 M6x35
Tightening torque: 8 Nm (A 8.8 bolts)
Thread of mounting holes: M6x10
Sealing rings: N. 5 OR type 2050 (12.42x1.78) - 90 Shore N. 2 OR type 2037 (9.25x1.78) - 90 Shore

DZC5R MOUNTING SURFACE

ISO 4401-05-05-0-05
(CETOP 4.2-4 R05-350)

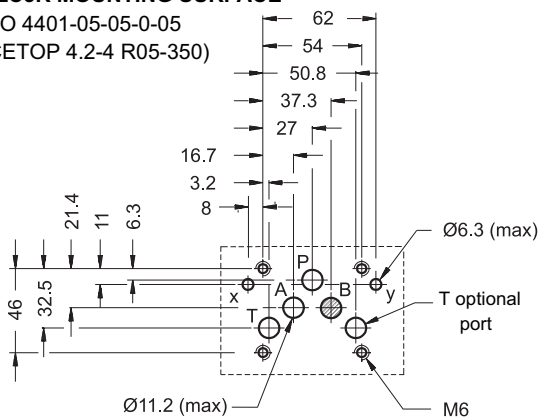

DZC5 MOUNTING SURFACE

CETOP 4.2-4 P05-350

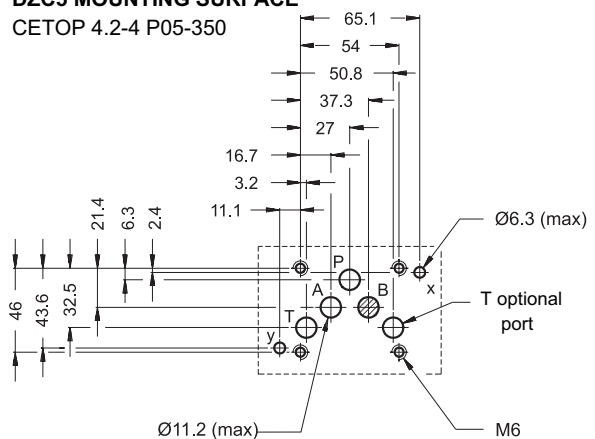

7 - DZC7 OVERALL AND MOUNTING DIMENSIONS

dimensions in mm

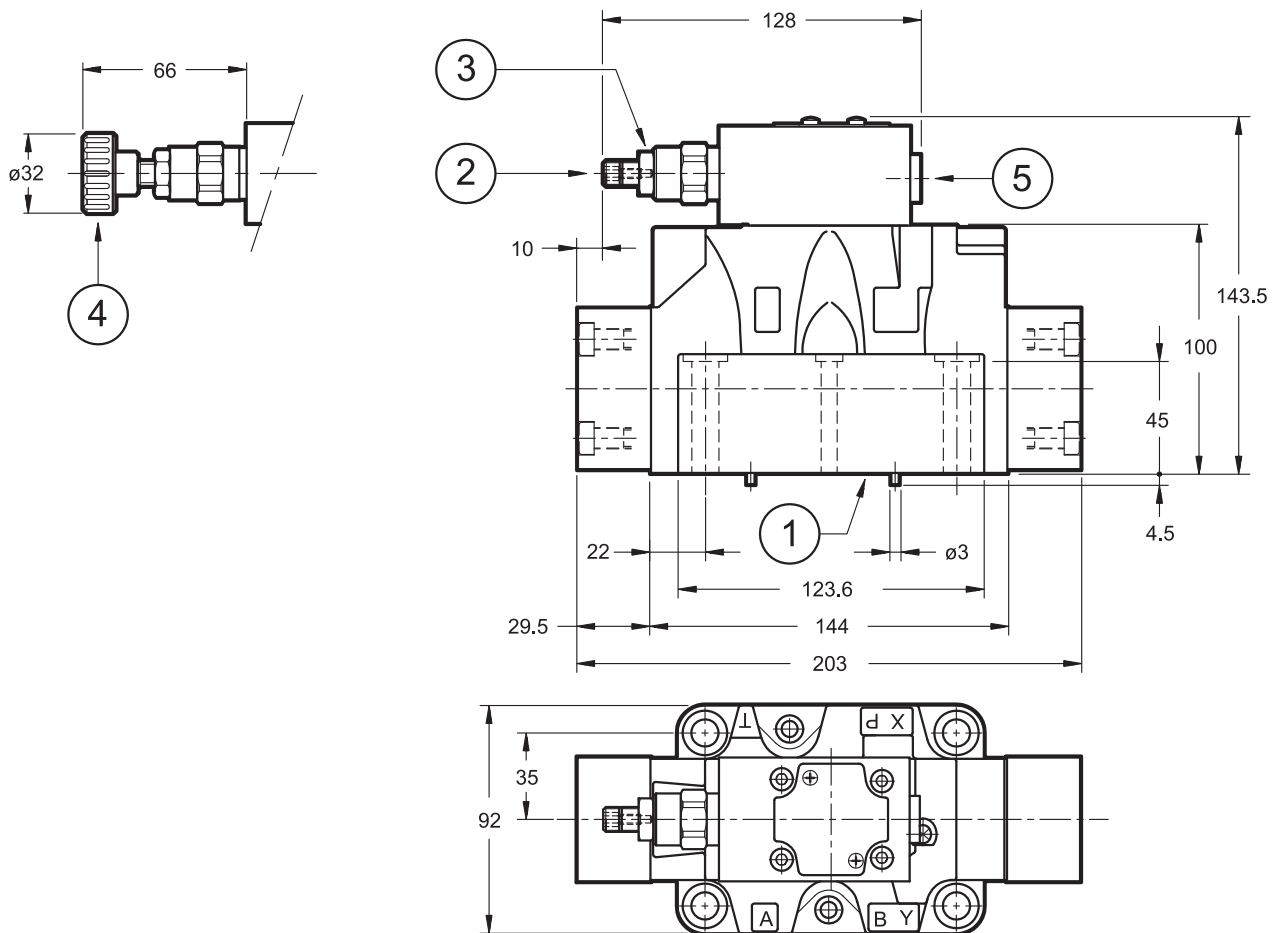

1	Mounting surface with sealing rings
2	Countersunk hex adjustment screw: Spanner 5. Clockwise rotation to increase pressure
3	Locking nut: spanner 17
4	Adjustment knob: M1
5	Pressure gauge port 1/4" BSP

Single valve fastening:	N. 4 SHC ISO 4762 M10x60 bolts N. 2 SHC ISO 4762 M6x60 bolts
Tightening torque M10x60:	40 Nm (A 8.8 bolts) M6x60: 8 Nm (A 8.8 bolts)
Thread of mounting holes:	M6x18; M10x18
Sealing rings:	N. 4 OR type 130 (22.22x2.62) - 90 Shore N. 2 OR type 2043 (10.82x1.78) - 90 Shore

MOUNTING SURFACE

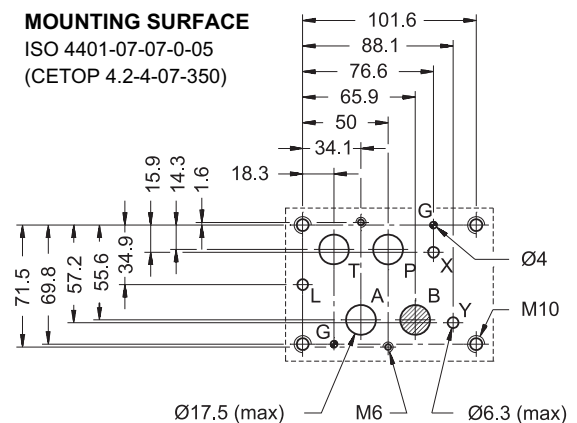
 ISO 4401-07-07-0-05
 (CETOP 4.2-4-07-350)

8 - DZC8 OVERALL AND MOUNTING DIMENSIONS

dimensions in mm

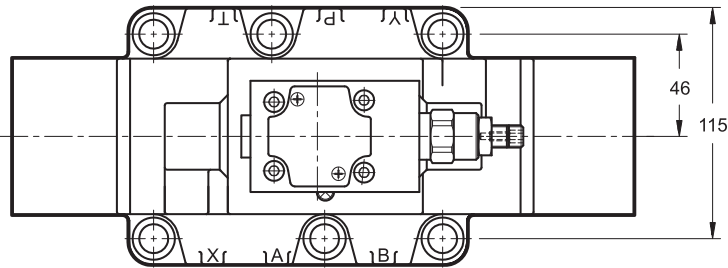
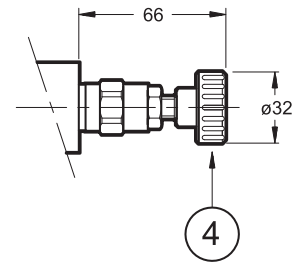
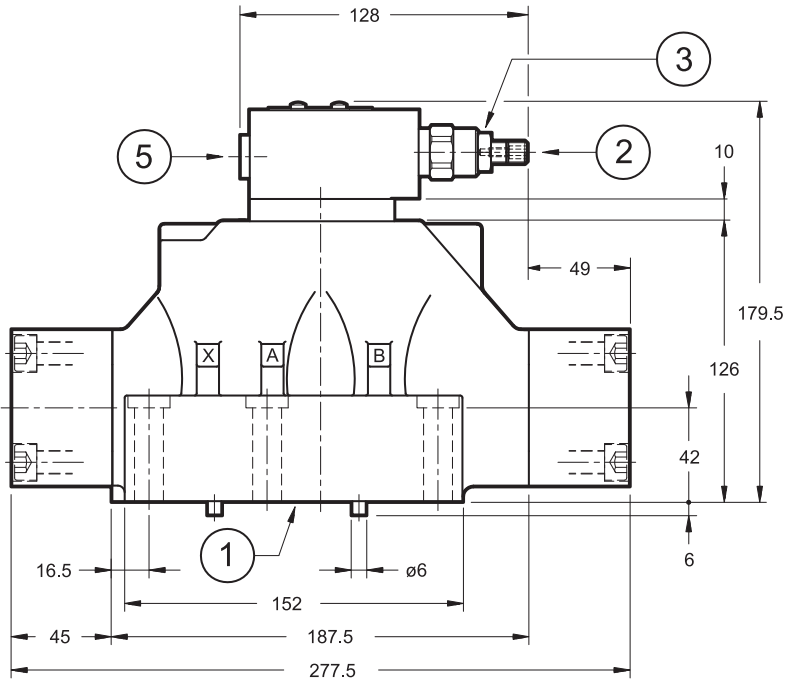

1	Mounting surface with sealing rings
2	Countersunk hex adjustment screw: Spanner 5. Clockwise rotation to increase pressure
3	Locking nut: spanner 17
4	Adjustment knob: M1
5	Pressure gauge port 1/4" BSP

Valve fastening: N. 6 SHC ISO 4762 M12x60 bolts
Tightening torque: 69 Nm (A 8.8 bolts)
Thread of mounting holes: M12x20
Sealing rings: N. 4 OR type 3118 (29.82x2.62) - 90 Shore N. 2 OR type 3081 (20.24x2.62) - 90 Shore

MOUNTING SURFACE
ISO 4401-08-08-0-05
(CETOP 4.2-4-08-350)

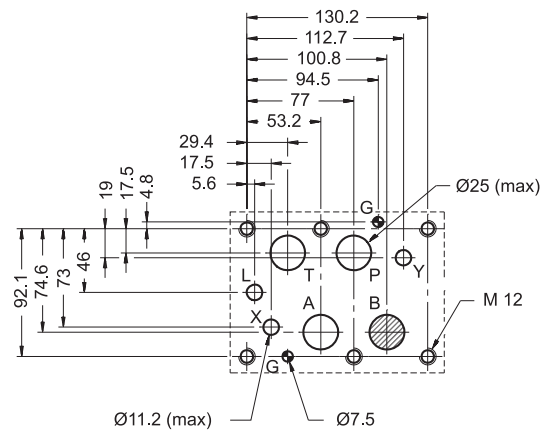



9 - SUBPLATES (See catalogue 51 000)

		DZC5	DZC7	DZC8
Model with rear ports		PME4-AI5G	PME07-AI6G	
Model with side ports		PME4-AL5G	PME07-AL6G	PME5-AL8G
Thread of ports:	P - T - A - B X - Y	3/4" BSP 1/4" BSP	1" BSP 1/4" BSP	1½" BSP 1/4" BSP



DZC*
SERIES 10



DIPLOMATIC OLEODINAMICA S.p.A.
20015 PARABIAGO (MI) • Via M. Re Depaolini 24
Tel. +39 0331.895.111
Fax +39 0331.895.339
www.diplomatic.com • e-mail: sales.exp@diplomatic.com

